

MAICO

Service Manual



SQUARE BARREL ENGINE SECTION

NOTE: ALL THREADS ARE RIGHT HAND
(Clockwise to tighten - counter
clockwise to loosen).



I. Preparation For Disassembly Of The Engine

1. All dirt, mud, dust, and foreign material must be thoroughly removed from the exterior of the engine assembly before removal and disassembly.

II. Engine Removal And Disassembly

1. Drain the transmission oil by removing the drain plug located at the underside of clutch cover just ahead of the foot rest. The plug has a 17 mm hex. Remove foot rests. The transmission/Primary holds 1000cc (1 Liter).

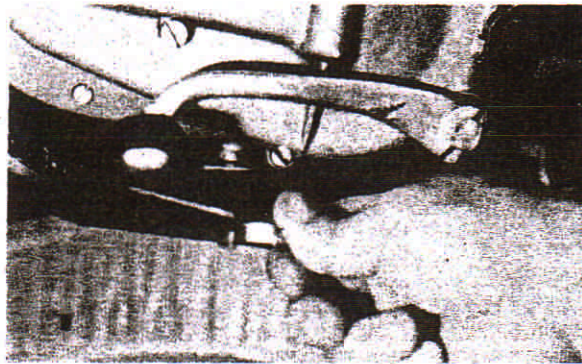

2. Remove carburetor - medium screw driver.

Note: Disconnect wire to coil if motorcycle is equipped with external coil. The coil is located under the gasoline tank.

11. Remove the ignition cover - medium blade screw driver. Not necessary for transmission repair.

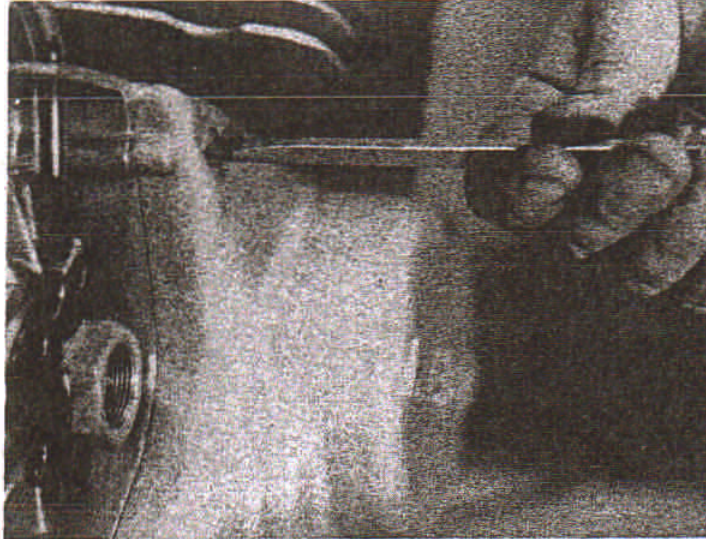

12. Remove the three screws holding the magneto housing - medium blade screw driver. Not necessary for transmission repair.

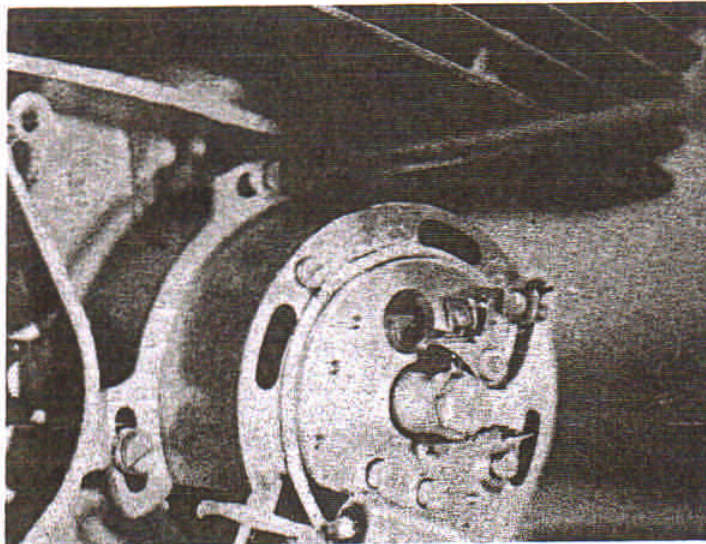

13. Remove the electrical wire going to the coil from the points and pull through the case removing the rubber grommet.

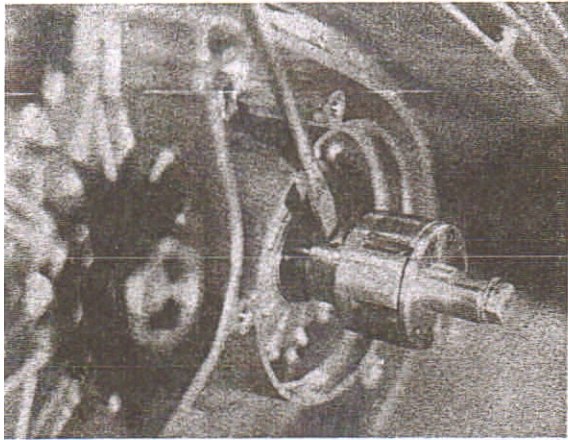

14. Remove the magneto rotor - small blade screw driver, 8mm wrench, impact slide hammer puller. We recommend the use of a slide hammer puller as shown.

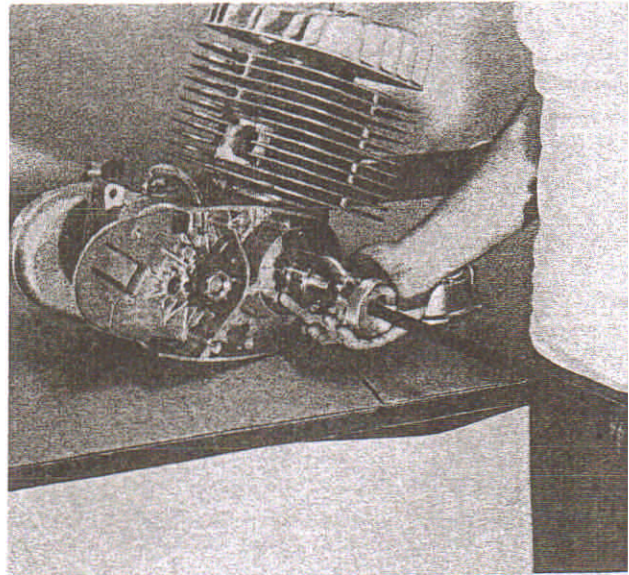
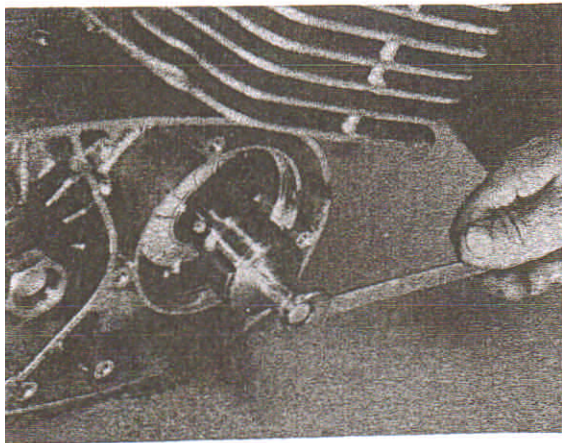

15. Remove cylinder head - 13mm socket.

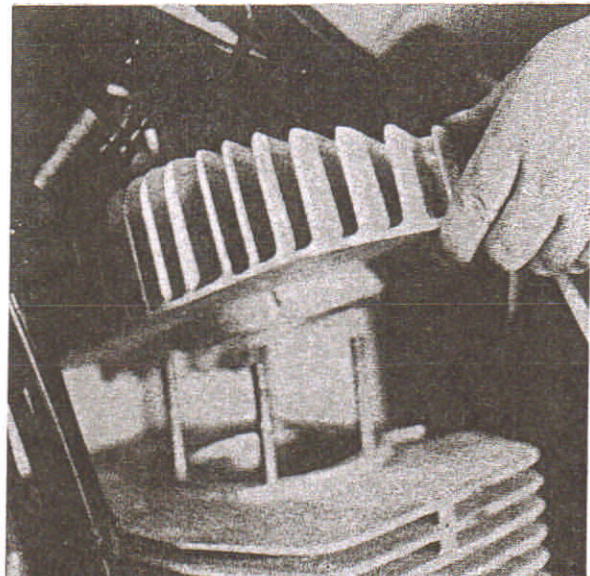
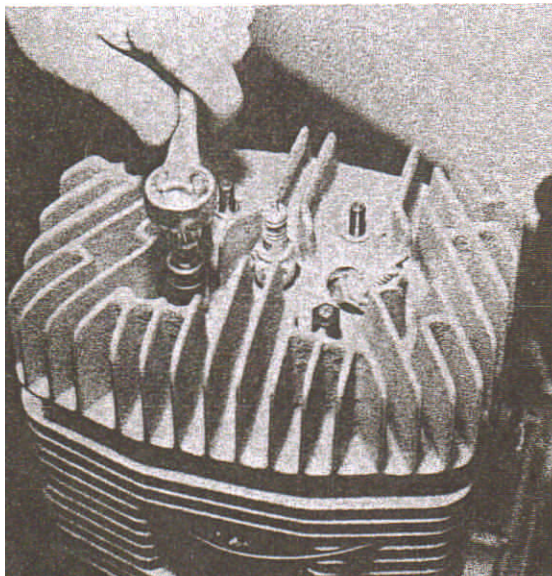

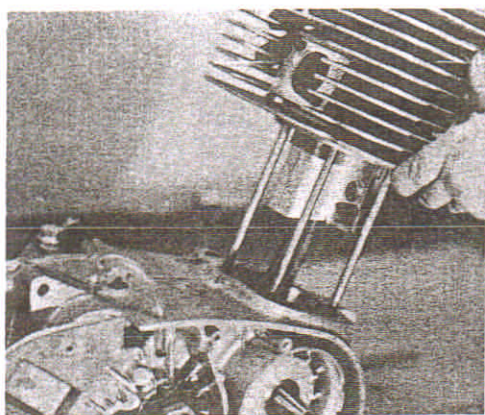

16. Remove cylinder

NOTE: To remove cylinder with engine in the frame, remove the studs with a small vise grip pliers. Push the piston to BDC and remove the cylinder.

17. Remove pin clips - needle nose pliers. Push pin through and remove piston and bearing. Note the shop towel in the top of cases to keep foreign objects from falling into the lower end. Do not reuse piston pin clips.

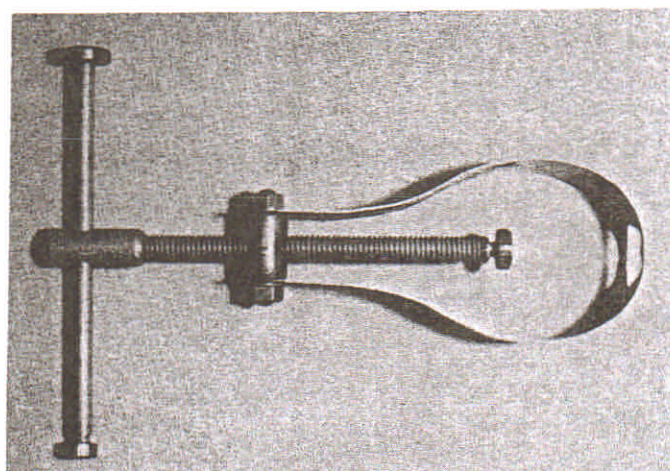
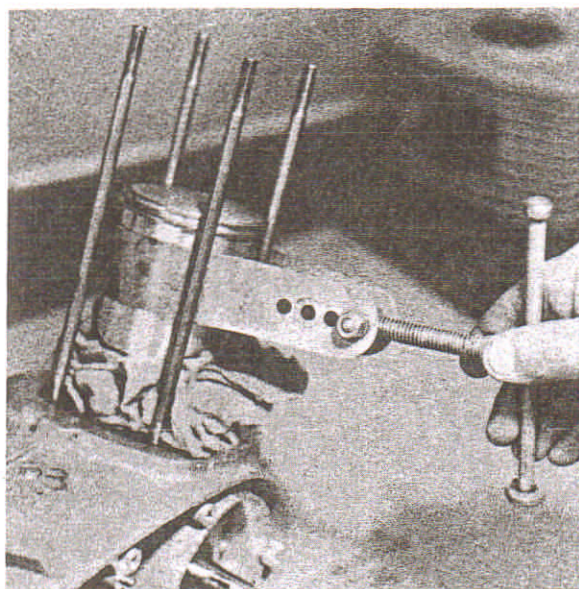
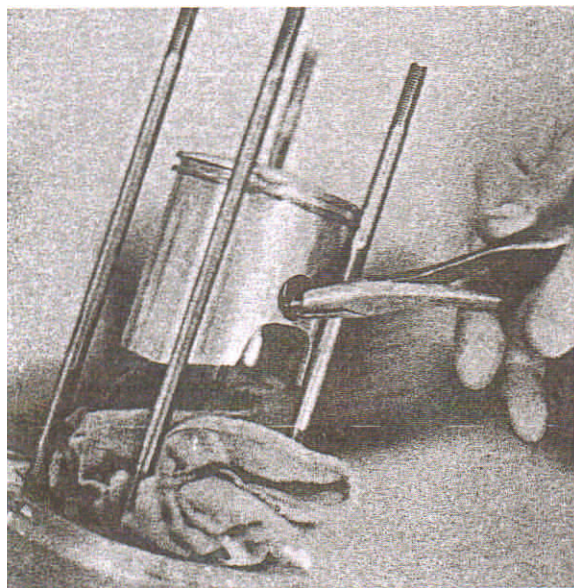

18. Place engine in engine stand with clutch cover up.

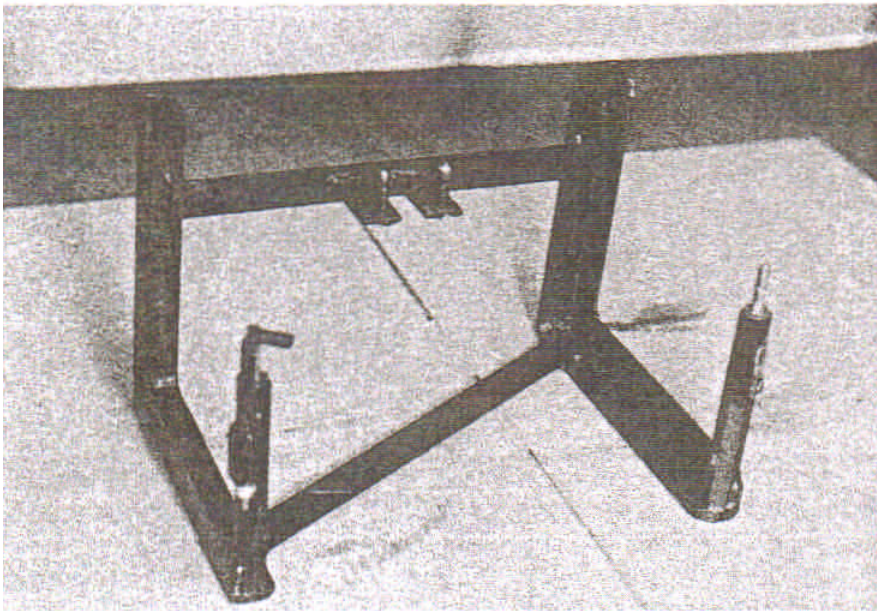
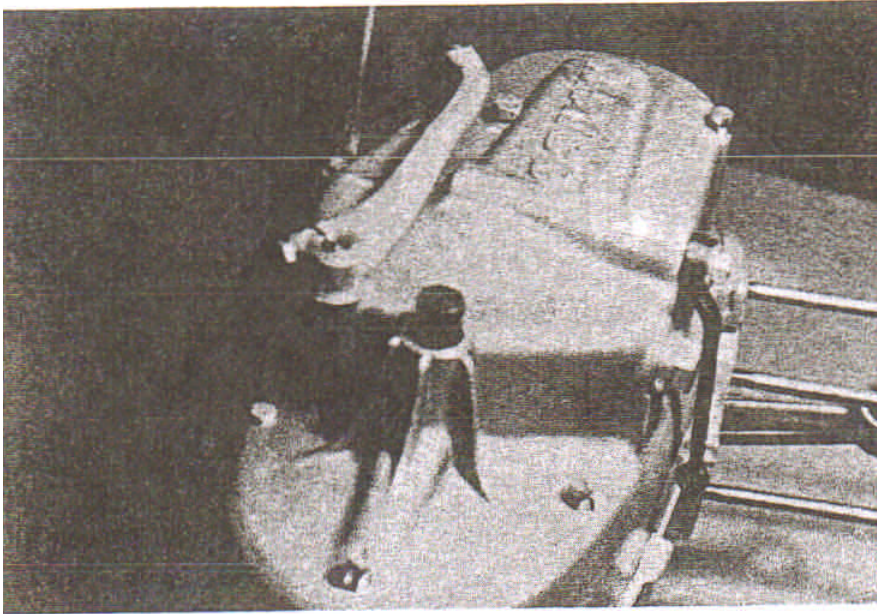

19. Measure the piston and measure the cylinder bore. If the cylinder bore is greater than .006 inch, replace the piston. It is wise to check the cylinder bore in at least 3 places; top, mid and bottom to be sure that the cylinder is round and is true from top to bottom.

Rebore when the total deviation in the cylinder is greater than .006 inch from a new piston.

A new piston shall have .002 inch clearance between piston and cylinder wall measured at bottom of skirt. The machine will require 75-100 miles break in prior to racing.

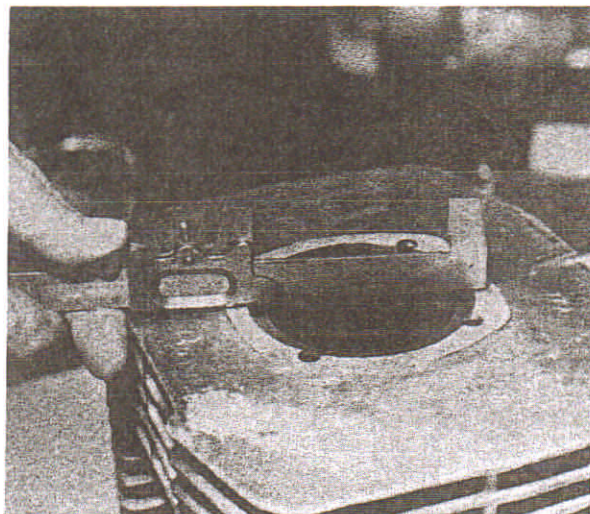
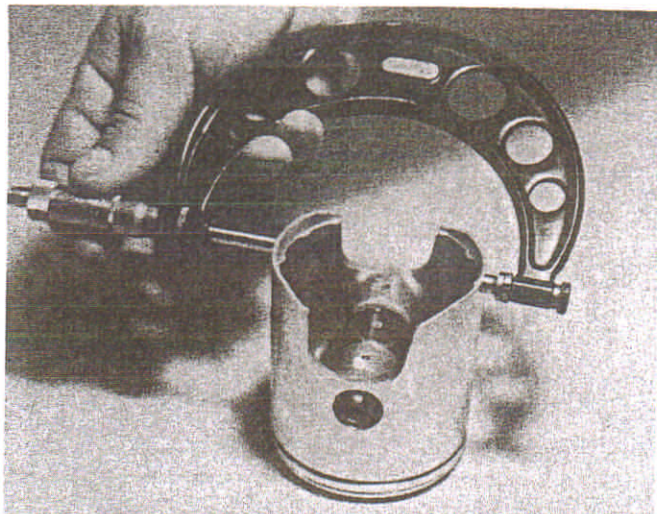

20. The piston rings shall be checked for end gap. A new ring has .010 inch end gap. When end gap exceeds .016 inch replace piston rings.



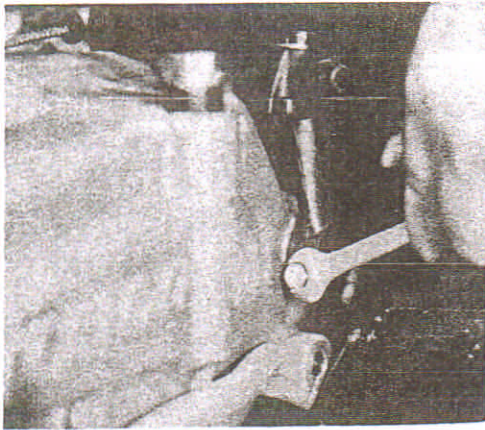

21. Remove:

A. Kick Starter

1. 360-250 - Remove snap ring and loosen pinch bolt - ice pick and 17mm wrench.

2. 400-501 - Remove 6mm bolt - 10mm wrench.

B. Remove seven 6mm screws from the cover - medium blade screw driver.

C. Pull the cover straight up

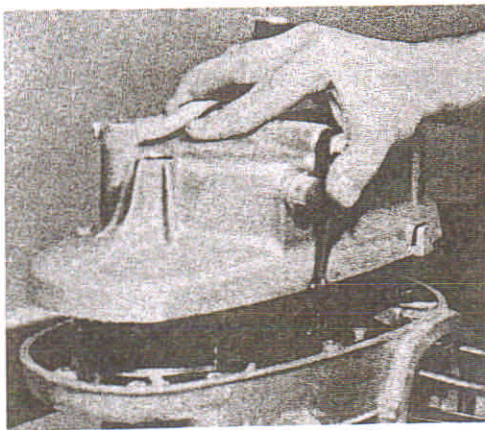

Note: For servicing clutch with engine in the frame, lay the machine over with the right side down. Pull the plastic transmission vent hose out of the case just above the chain. Turn the hose 180° so that transmission oil will not run out. Having the motorcycle level will greatly assist when replacing the clutch springs.

22. Remove the clutch snap rings with special puller and two small blade screw drivers.

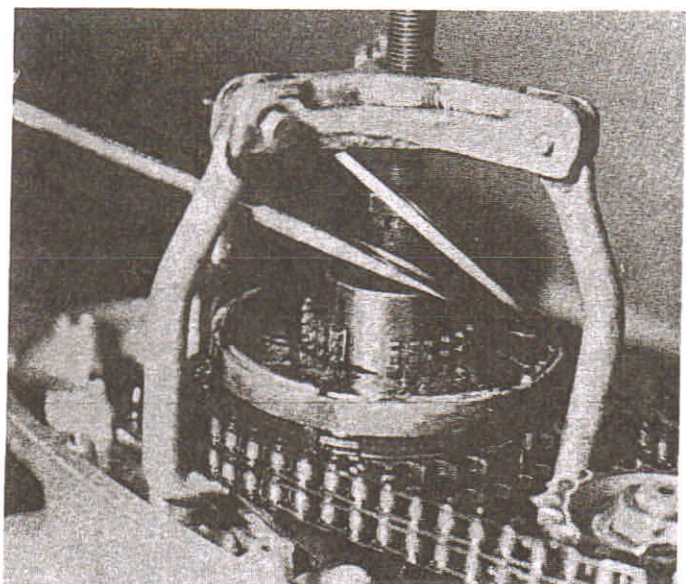
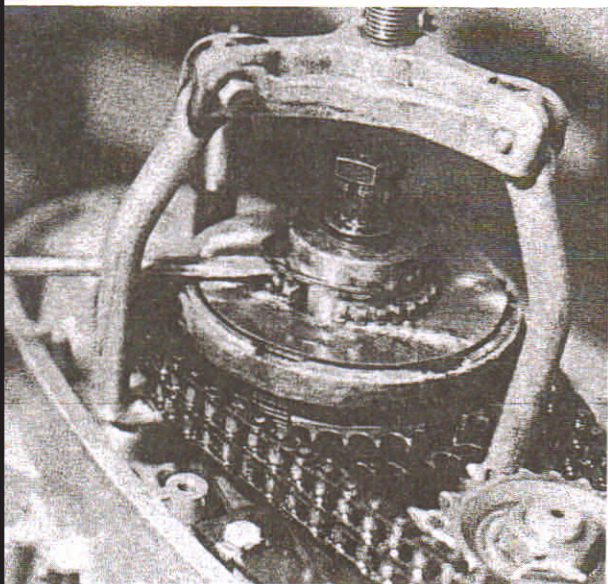

23. Remove by hand the clutch plates, clutch guide, and note direction of fiber plate and spring stack up.

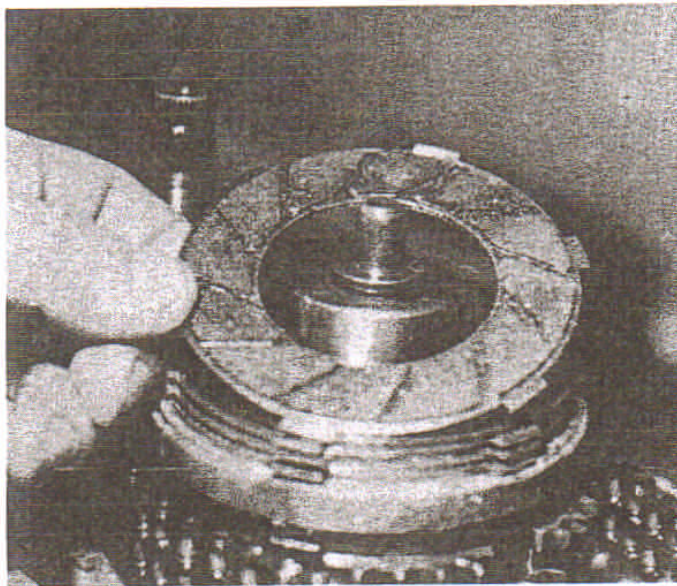
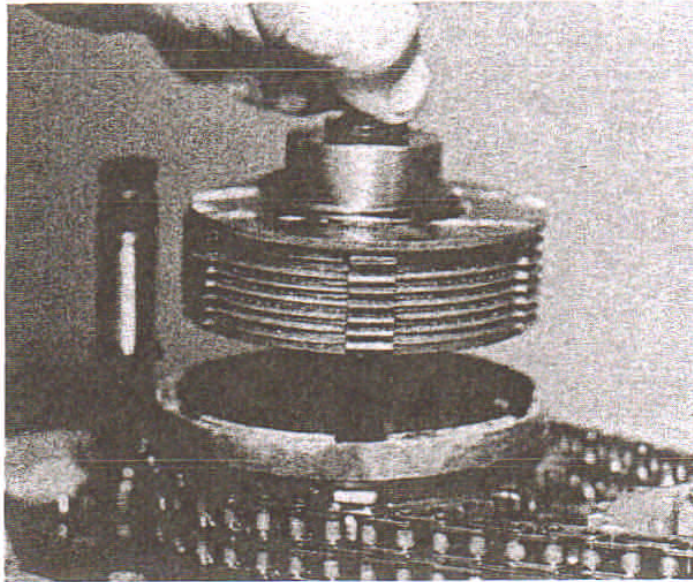

24. Clutch spring height
new .075 - replace .070

25. Clutch spring heavy 360 - 400
Place two springs face to face,
then add two more springs one
on each side, making a set of
4 springs. Use 18 springs, ma-
king 4 1/2 sets. Twenty springs
may be used - 5 sets - for more
spring pressure.

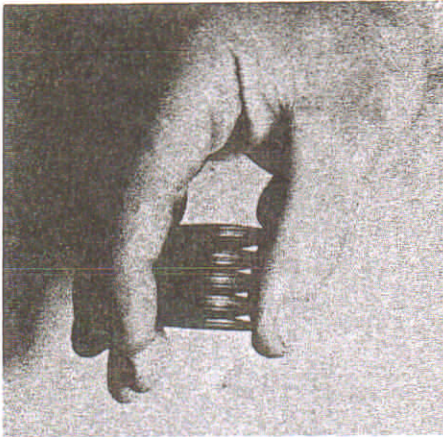

26. Clutch spring light 501 and
early oval barrel 250 and 360.
Take two springs face to face
for set of 2. Use 20 springs,
making 10 sets of 2 springs.

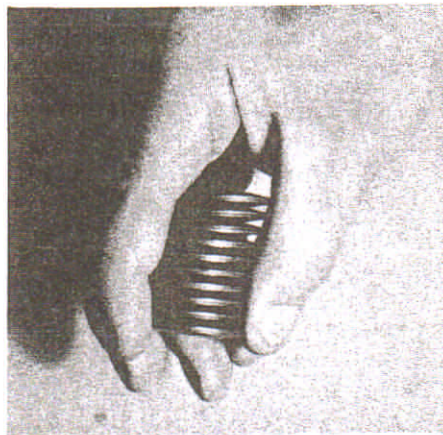

Late model 400 and 501
clutches that are the light
weight model uses 18 springs
stacked as shown above.

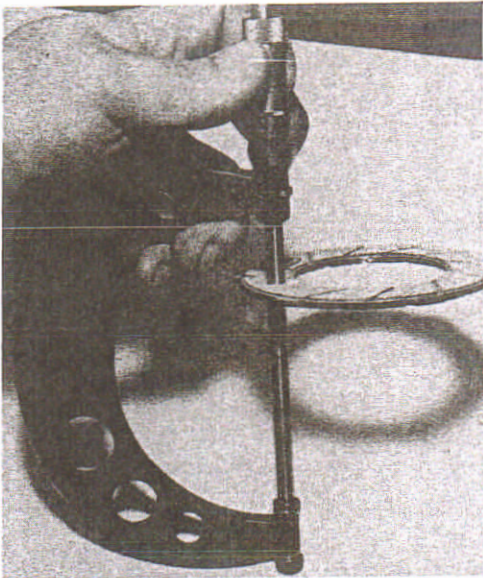

27. This picture shows the proper sequence of assembly for the all steel clutch. It is recommended to use 20 springs when reassembling.

For 250, 360 and early 400 only.
One fiber plate.

Thickness new .150
Thickness replace .145

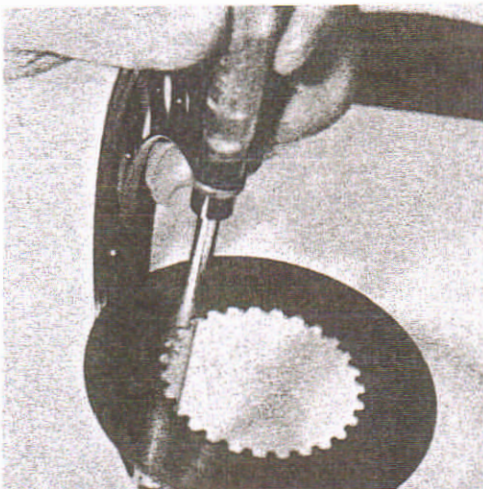

Driven plate - 6 required.

Thickness new .050
Thickness replace .045

Note: When all fiber clutch is used this plate will have no wear. Check for flatness.

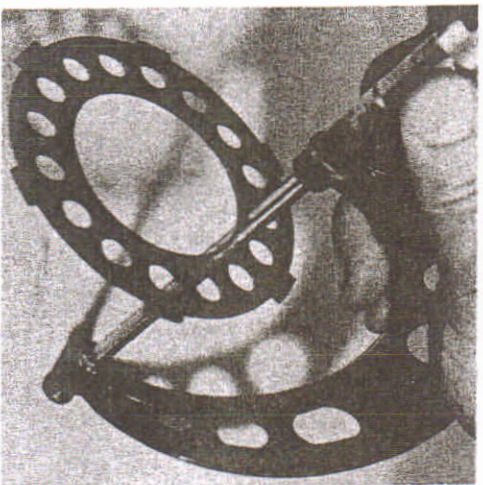

Driving plate - 6 required.

Thickness new .085
Thickness replace .080

CLUTCHES

27a. 250 & 360 fiber clutch
 5 fiber plates 4 steel plates 18 to 20 springs double

27b. 250 & 400 steel clutch. 20 springs double

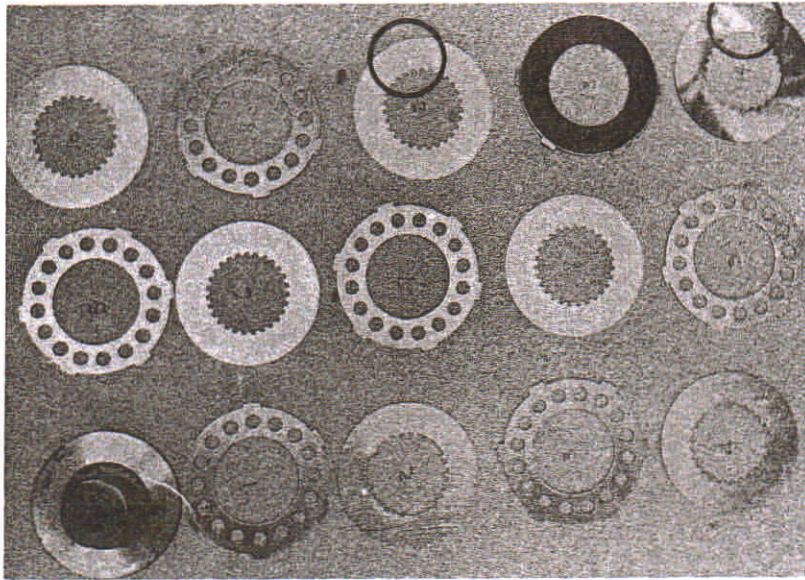

27c. 400 & 501 big clutch
 First design big clutch
 used in most 1971 400cc
 moto crossers.
 6 steel splined plates
 7 fiber plates
 1 terminal plate - Snap
 ring it into terminal
 plate groove.

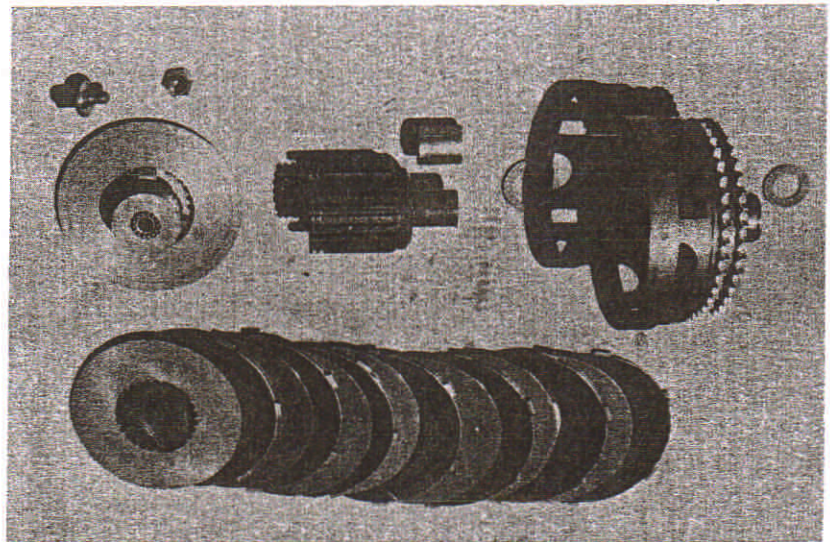

Note: Clutch body (center of
 clutch that is splined)
 is longer on 1st. design
 clutch than 2nd design.
 This clutch uses 20
 springs stacked single
 () () () () () () () () () ()

Note: The clutch plates
 shall be installed to
 throw the oil out.

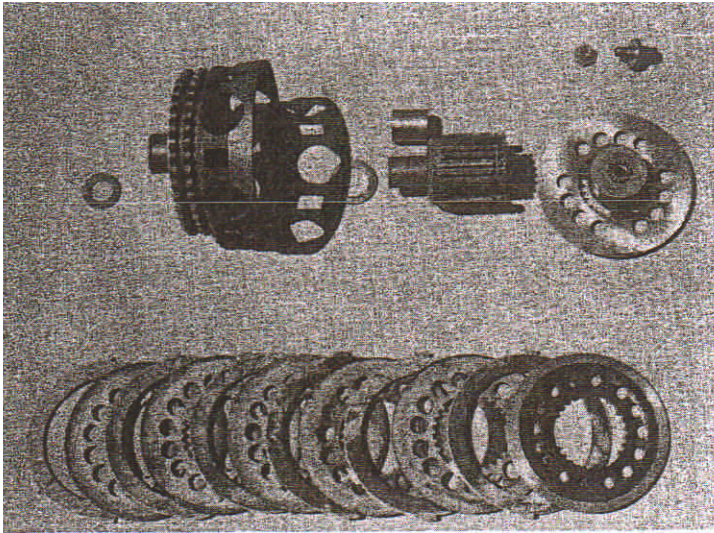

27d. Second design big clutch used in all 1972 400 & 501cc models.
5 steel splined plates
6 fiber plates
1 terminal plate. The narrow machined ring goes outside. The wide machined band goes inside.

Note: This clutch body (center of clutch that is splined) is shorter than the 1st-design-

This clutch uses 18 springs stacked single
() () () () () () () () () () () () () () () () () ()

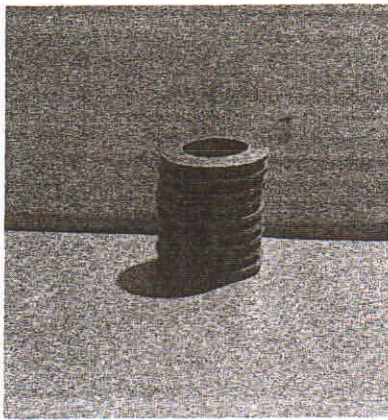

Note the heavy washer between the inner & outer clutch bodies.

The spacer ring not shown may go either on top or under the spring washers.

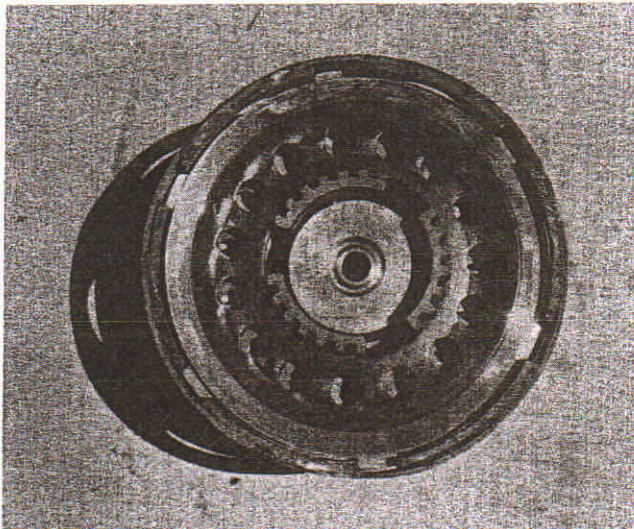

NOTES TYPICAL TO ALL CLUTCHES

Note: The clutch plates shall be installed to throw the oil out.

Note: The clutch throwout bearing requires 14 ball bearings on all models.

Note: The clutch nut must be installed with "Loctite". If the clutch nut comes loose two gears will engage at the same time.

27e. This is the engine flywheel used on the 501 only.

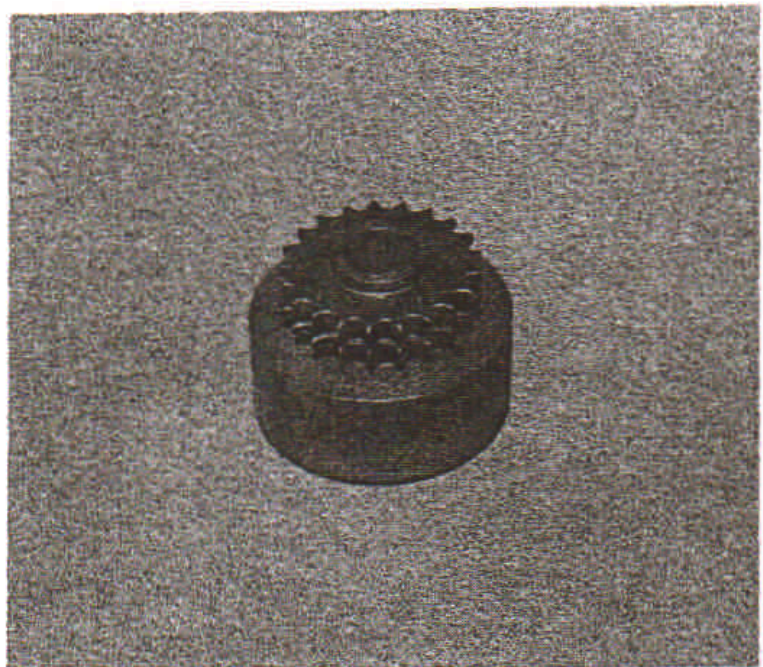

28. Remove the lock tab from the clutch guide nut by lifting out. The lock tab is reuseable. Shown is a new lock tab and one properly bent to secure the nut. Not used in 501.

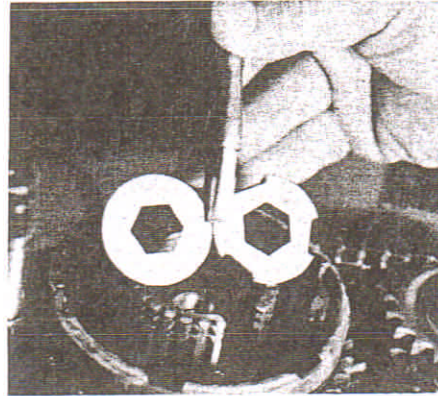
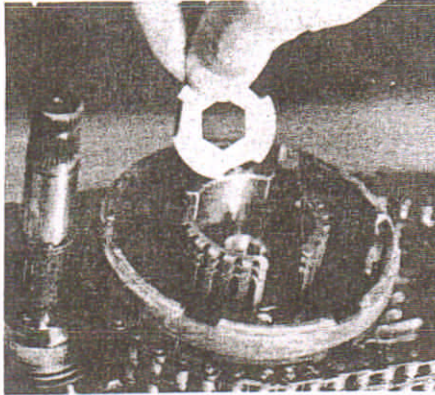

Use Loctite on the 501 clutch nut.

NOTE: If the clutch nut comes loose the transmission will engage two gears at once.

29. Remove clutch center - special clutch holding tool and 17mm socket.

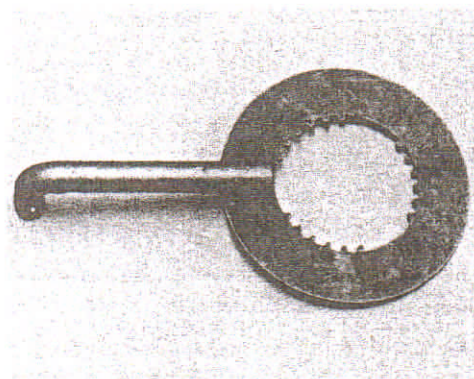
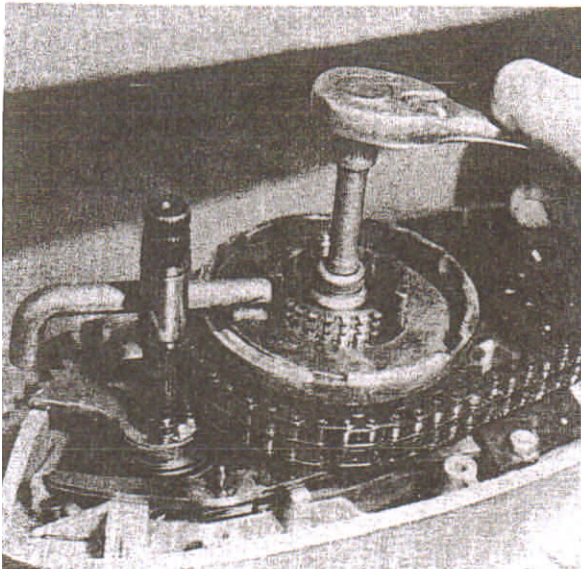

Note: Removing the clutch center without the Special clutch tool can cause damage. This damage will cause the clutch plates to bind up and the clutch will slip or not properly release.

30. Pull clutch center from clutch case, remove bronze bush.

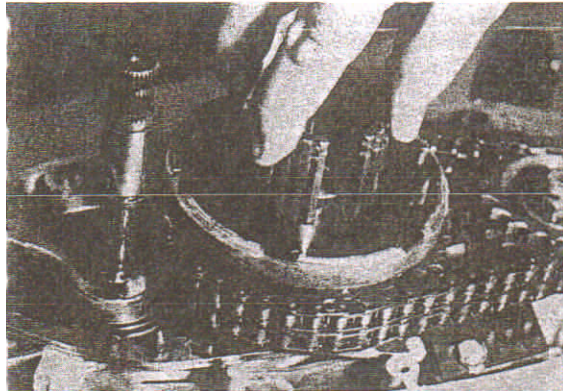

31. Remove clutch case and primary chain and clutch thrust washer. Note condition, if bent or grooved replace washer.

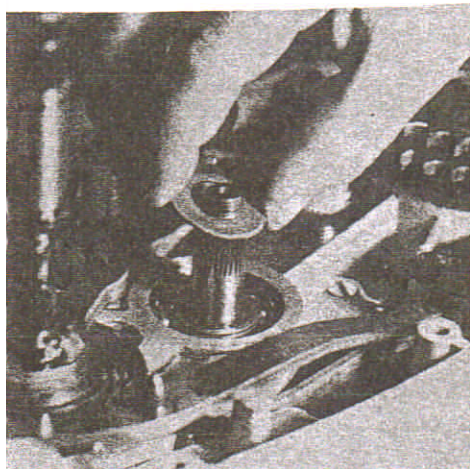
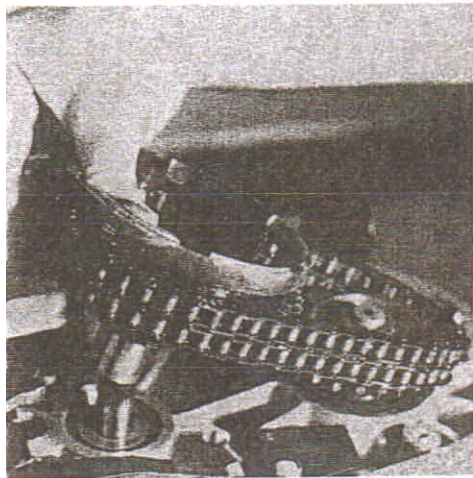

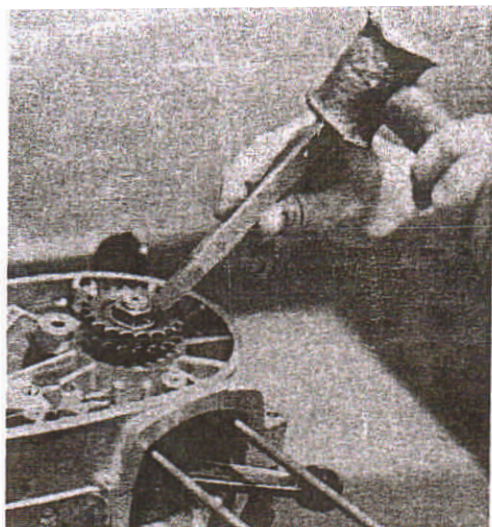

32. Engine sprocket

1. 250-400cc Remove lock tab from engine sprocket nut - chisel and hammer.
2. Keep the flywheels from rotating by inserting pin between connecting rod and case. Remove engine sprocket nut and lock washer, pull sprocket, and spacer.

Tools, 3/8" pin, large screw driver and 24mm wrench.

Note the pin that keeps the flywheels from rotating. The pin is inserted between the con rod and the engine cases.

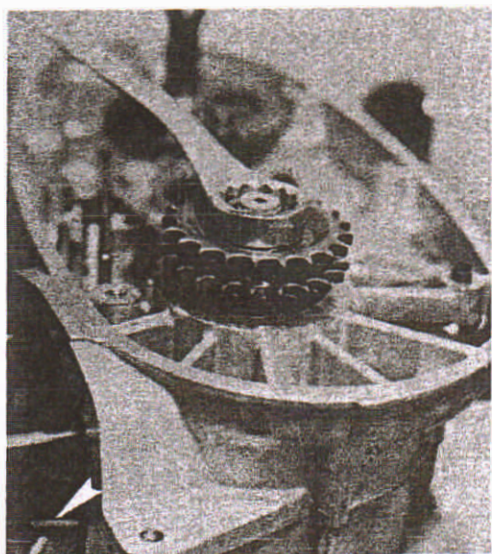

50lcc not shown

1. Remove sprocket nut
2. Remove external flywheel and the spacer ring.

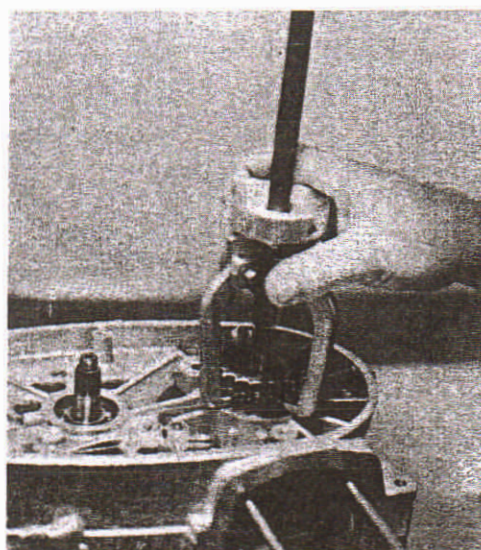
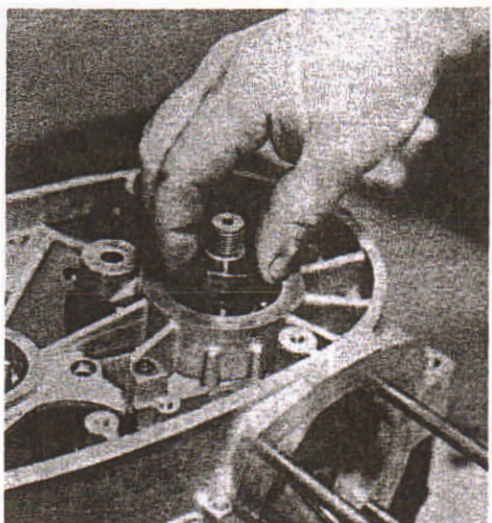

Note: When reassembling, grease back side of engine sprocket nut. Do not grease lock washer

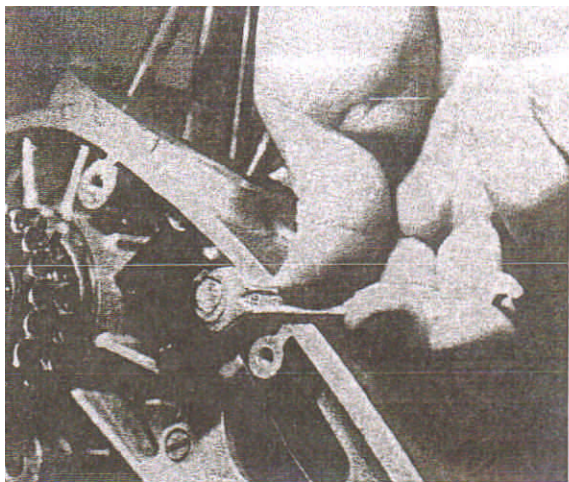

33. Remove lock tab, shift linkage cover plate, and shift linkage pull rod. 10mm wrench, chisel and hammer. See Misc. section for proper indexing of shift mechanism when reassembling.

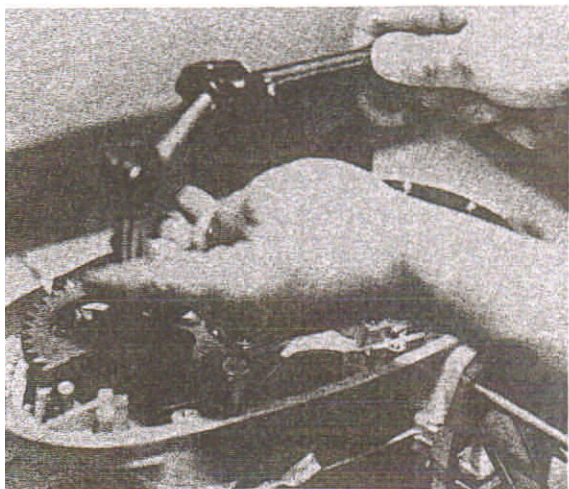

34. Remove kick starter shaft and spring by winding spring and lifting straight up.

35. 250 and 360 models have eight internal case screws. Large blade screw driver.

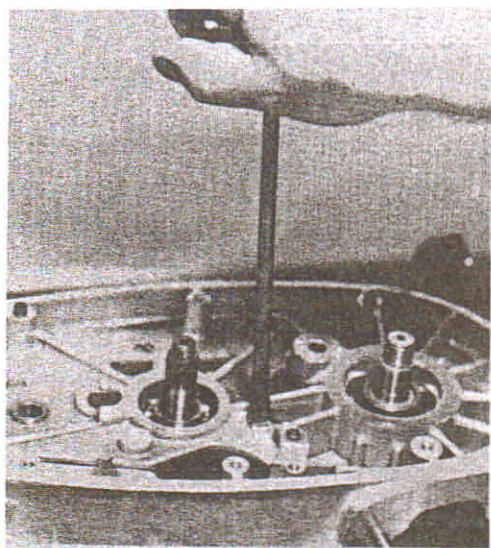

36. Late model 250, all 400's and 501's have seven internal case screws and one external. Large blade screw driver.

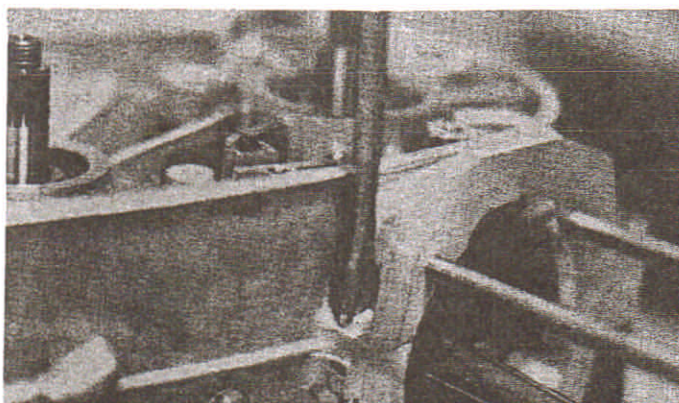

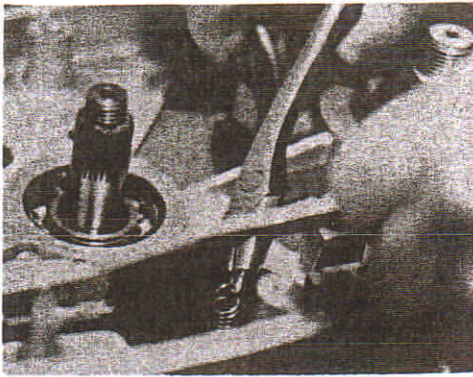

37. Remove spring from hook ratchet - needle nose pliers.

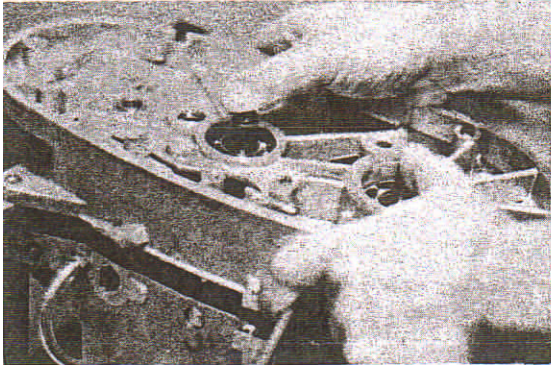

38. Remove left hand case - by hand and rawhide hammer.

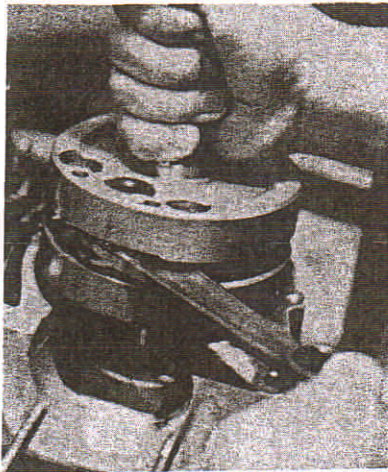

39. Remove crank shaft assembly - by hand.

40. Check flywheel alignment by rotating on knife edges. Max. misalignment is .002 inch at the end of the magneto shaft, re-align if necessary. This must be done by a motorcycle shop or a machine shop.

NOTE: It is suggested to reassemble the flywheels using Loctite grade 35 and Loctite primer grade T. To disassemble loctited flywheels heat to 450-500° F in an oven. Do not use a torch.

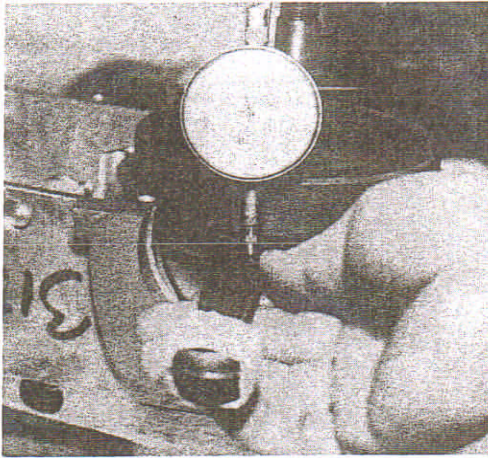

41. The connecting rod side play shall be .019 - .020 inch when new. A feeler gauge may replace the dial indicator. The thickness of the big end of the connecting rod when new is .665 to .670 inch. It is permissible to have more than .020 if the connecting rod has worn into the flywheel surface.

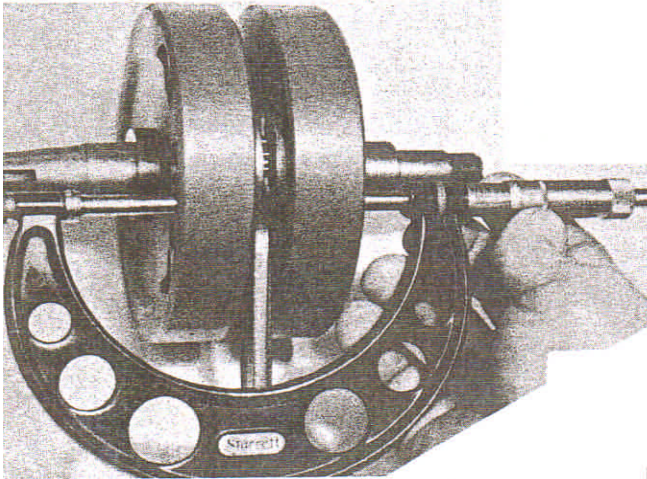

42. The reference distance across the flywheels is 2.475 - 2.490 inches. This dimension should be used as a reference only as the measurement of the side clearance of the rod is the only accurate method.

43. Remove shifting fork spindle by hand. Check to see that it is not bent.

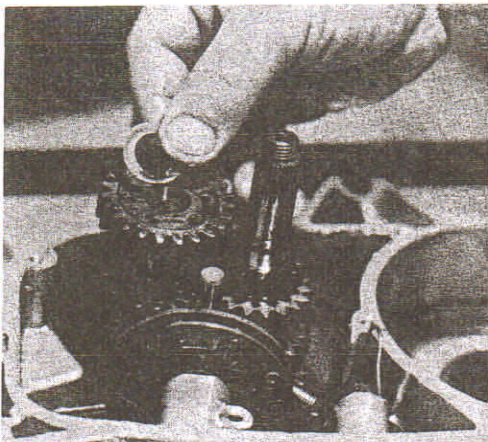
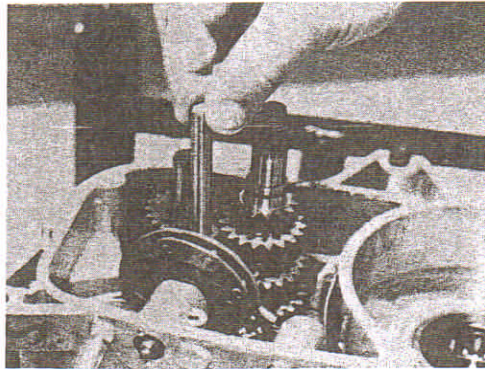

44. Remove gear stack - by hand. Note the shims. Some transmissions do not have shims. The shims control the 1st. gear tolerance to 0.3mm (.012). If the transmission is improperly shimmed it is possible to engage two gears at once.

45. Remove main shaft and shifting fork from lower scroll - by hand.

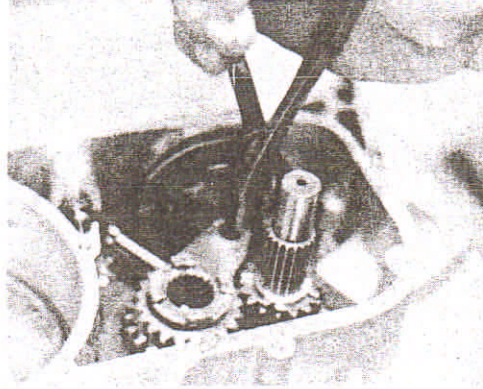
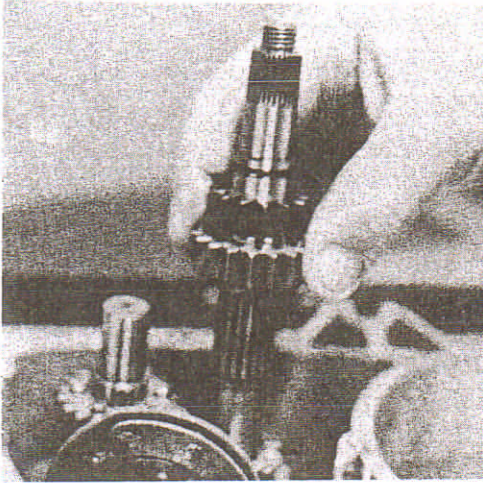

Grind here
.030 inch Max.

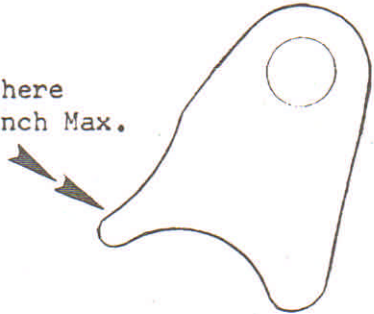

46. Remove lay shaft and shifting fork from upper scroll. CHECK to see if the shifting fork on the lay shaft is not touching second gear on the main shaft. If it is touching, grind for clearance.

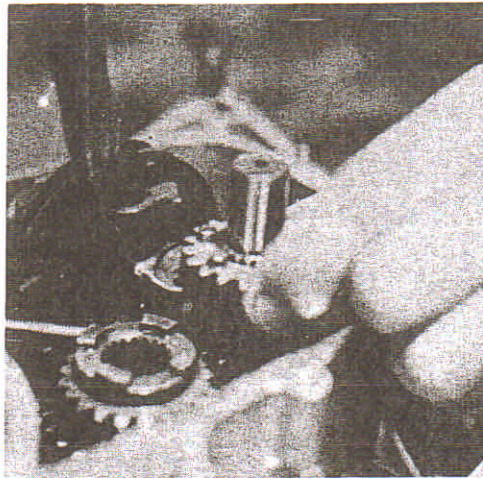
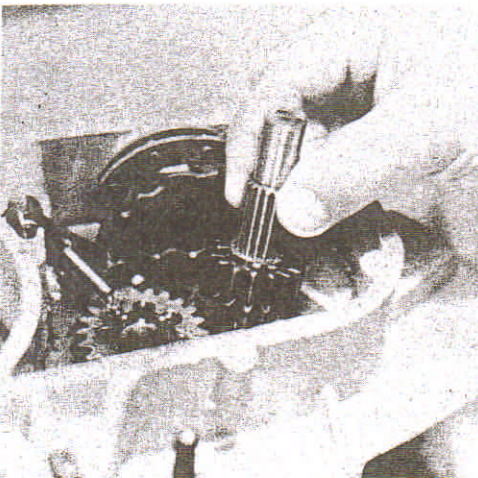

47. Gear stack showing the positioning of the shifting forks.

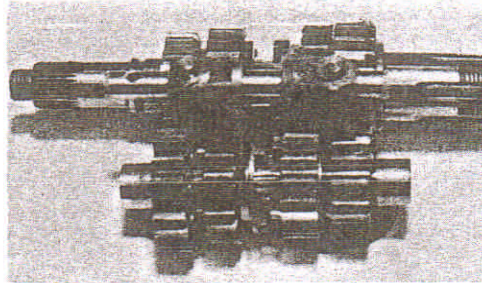

48. When fitting a new 1st gear to the lay shaft be sure it has the same amount of internal clearance (slop) as the 3rd gear on the lay shaft.

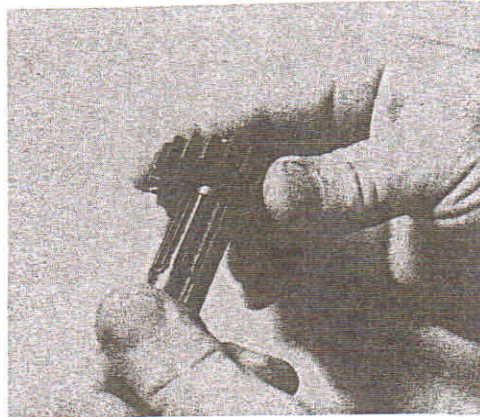
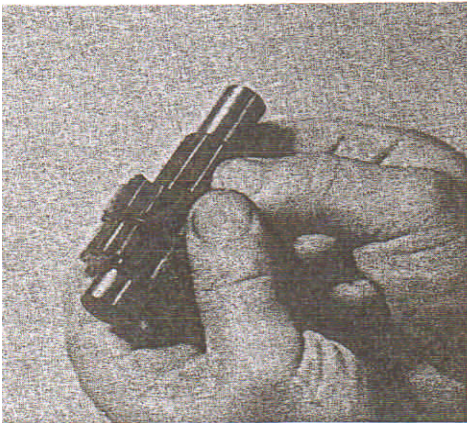

Close Ratio

	1	2	3	4	
Main	17	20	22	22	Teeth
Lay	20	18	16	13	Teeth
	1.99	1.52	1.23	1.0	Ratio to 1

Wide Ratio

	1	2	3	4	
Main	14	18	21	*	Teeth
Lay	23	19	*	*	Teeth
	2.78	1.79	1.29	1.0	Ratio

Primary Ratio 19/39=1.86 to 1

*Close Ratio gears are used in the wide ratio transmission at these locations

53. Replacing "O" rings on shifting cam spindle.

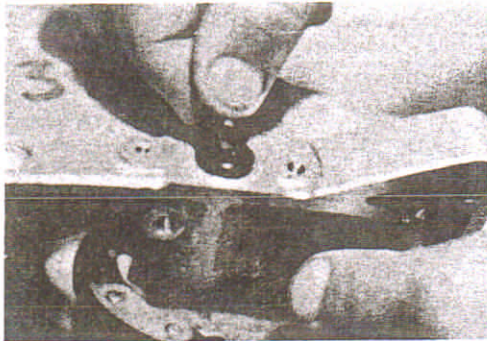

54. Remove engine seals and reinstall. Cases must be heated approx. 250°. Use an oven or hot plate. Use of a torch is not recommended.

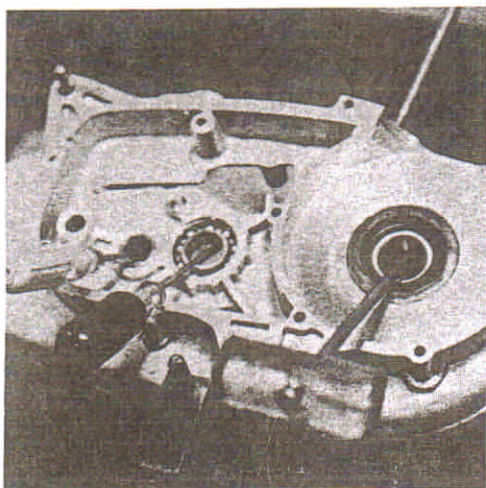

- 54-. 501 engine seals are external to the main bearings.

55. Cases must be heated approx. 250°F for removal of any bearing. The screw drivers are pointing to the bearing locations.

Crank shaft

Remove bearing race by locally heating race red and wedging a sharp chisel behind the race. Tap chisel lightly with hammer. The race may be removed with a blade puller once it has moved. It is suggested that the local motorcycle shop performs this operation. The seal land must be checked for any roughness caused by race removal.

56. The engine is now torn down far enough for major servicing. Do not disassemble any further unless absolutely necessary.

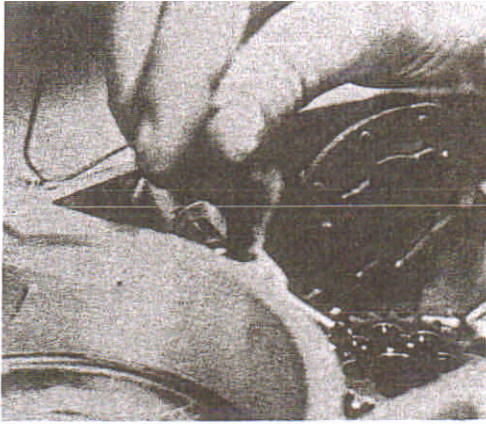

57. Removing the felt wick and retaining spring.

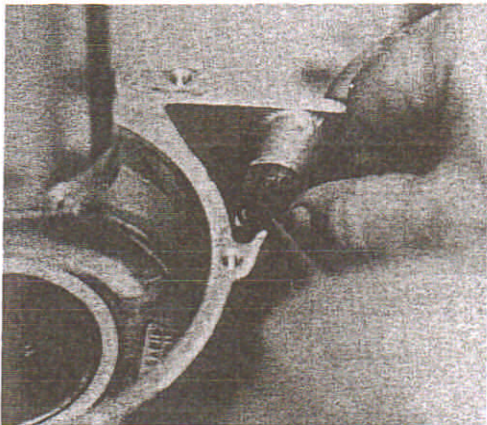

58. Removing the circlip from the shifting pawl.

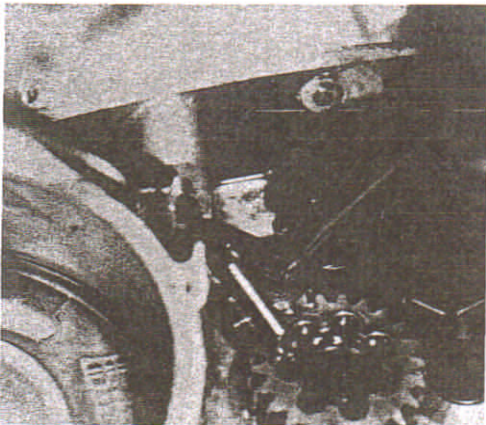

59. Removing the shifting pawl.

60. Removing the pawl spring.

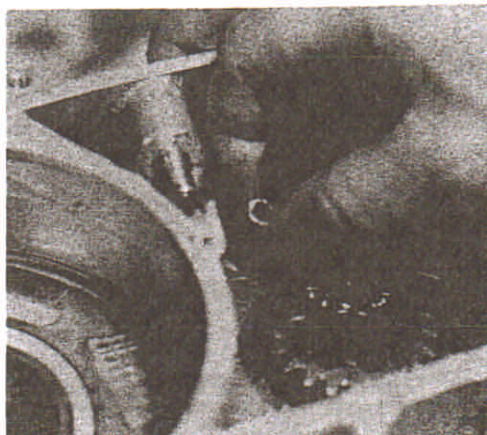

TECHNICAL SECTION

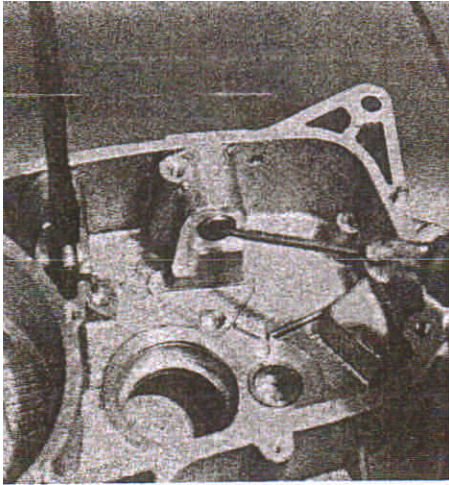

61. Shift cam bush and shift pawl stud are not normally removed, however, if worn, they are available from Maico parts distributor.

62. Fuel tap assy

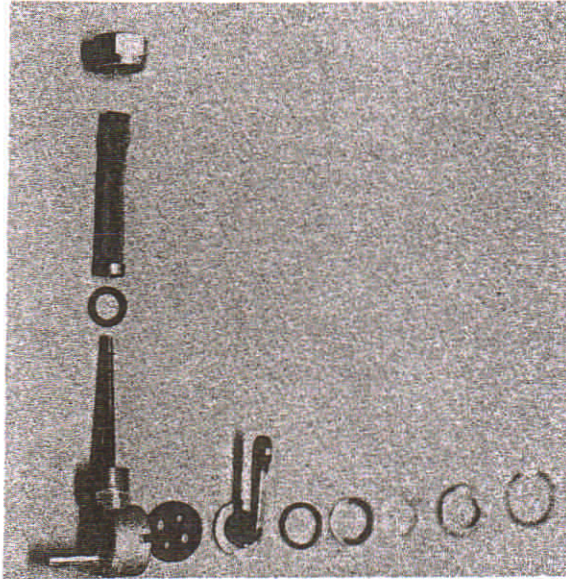

63. Ignition point assy

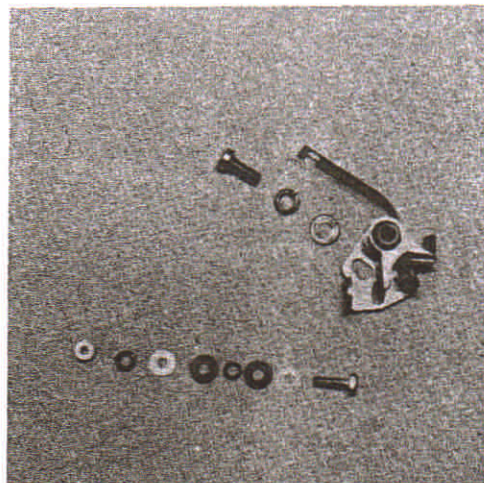

64. Carb adaptors, and air cleaner assy.

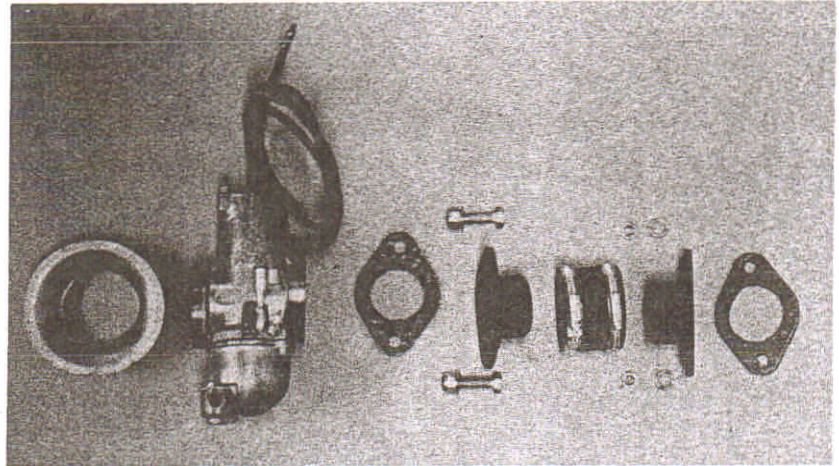
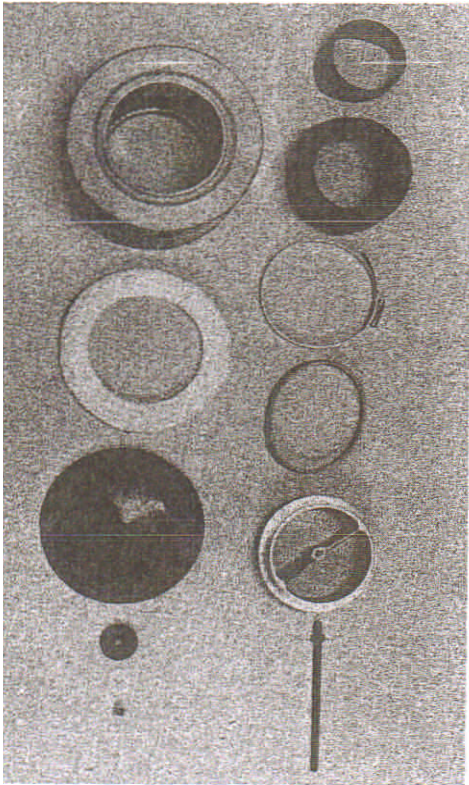

65. Foot starter assembly

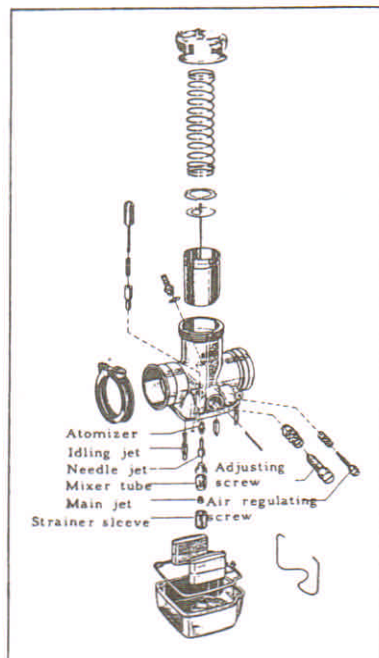
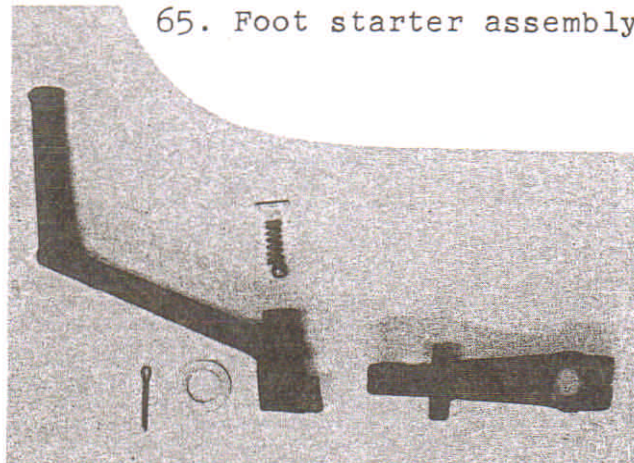

66. Ignition side assembly showing engine seal, roller bearing, and oil seal.

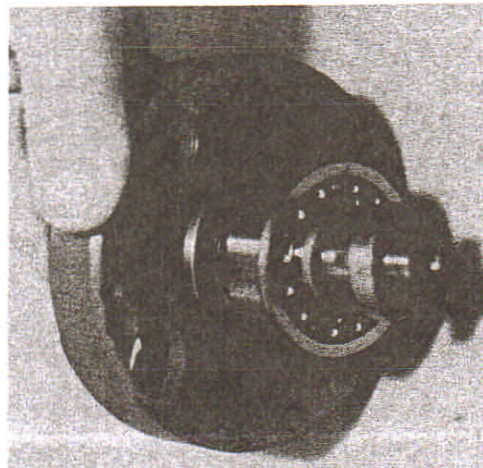

501 engine seals are external to the main bearings.

67. Drive side assembly showing seal and ball bearing.

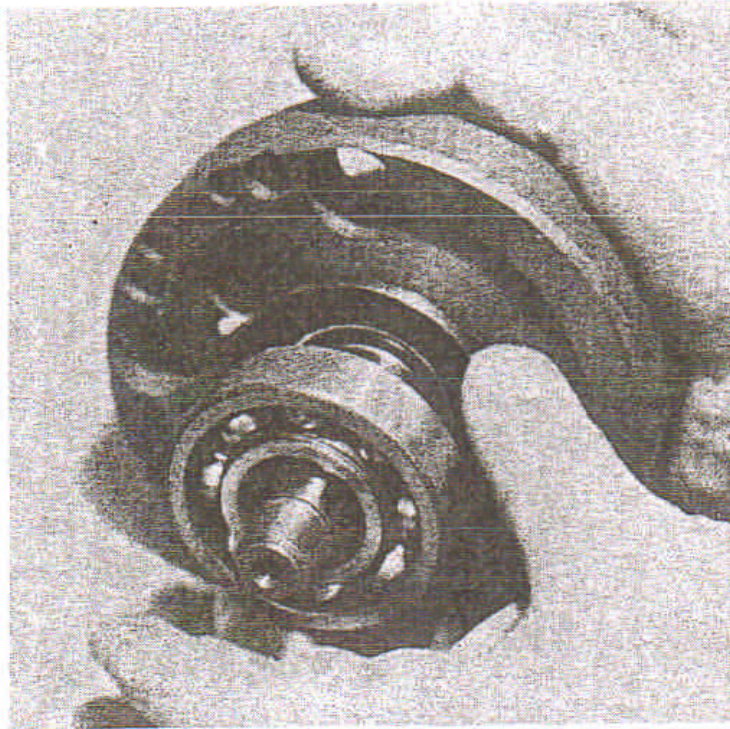

Engine:

Two-stroke, single cylinder engine
 Displacement: 250cc 400cc 360cc
 247cc 386cc 501cc
 Compression ratio: 12,3:1 12:1 12:1
 Fuel: Regular petrol
 Lubrication: Petroleum type racing oil,
 e.g. Castrol GP 50 wt. mixing
 ratio of 20:1 (5%)

Power transmission:

Seven disc moto-cross type clutch.
 Primary transmission by dual row primary
 chain 19T x 39T (1.86 to 1)
 Secondary transmission by chain drive
 5/8" x 1/4"). 12 teeth on gearbox sprocket
 and 53 teeth on rear wheel.

"S" Transmission 400 - 13T front - 52T rear
 250 - 11T front - 52T rear
 501 - 13T front - 52T rear
 "T" Transmission 400 - 13T front - 59T rear
 250 - 11T front - 59T rear
 501 - 13T front - 59T rear

Gearbox:

Transmission	4 Speed Heavy Duty	
	"T"	"S"
	Moto Cross	Cross Country
1st	1.99 to 1	2.78 to 1
2nd	1.52	1.79
3rd	1.23	1.29
4th	1.0	1.0

Oil capacity: 1 quart

Oil recommendation: Transmission oil SAE 40wt.
 for 250, SAE 90wt. gear
 oil for 400 & 501.

Carburettor: 250 400 501

Setting	250	400	501
Ring:	1/36/101		
Main jet:	180	185	180
Idling jet:	35	35	35
Needle jet:	280	285	280
Needle position:	3	3	3
Air screw opening:	1 1/2	1 1/2	1 1/2

Air filter:

Moto-cross type with paper element.

Piston & Flywheel data:

Flywheel assembly. Side play of connecting
 rod shall be .019-.020. Replace .023 or
 greater.
 Distance across flywheels outside to outside
 2.475. Reference only.
 Run out when supported on bearing area &
 measured at extreme end of magneto taper
 shall not exceed .002 inch.
 Timing side bearing - up & down play .010
 inch max.
 Piston ring end gap - .003 per inch of
 diameter.
 Cylinder sleeve to cylinder new .013
 interference when replacing turn sleeve
 to - .004-.006 interference.
 Piston to cylinder clearance .002 inch
 for 250 & 400. 501 shall be .0025 inch.

Ignition:

Appt. magneto separate high-tension coil.
 Timing: 250=2.9BTDC, 400=3.6 BTDC,
 501=3.6 BTDC
 Contact breaker gap: .014-.018"(0.35-0.45)
 Spark plug: Champion L3G=250, L2G=400,
 N2G=501

Frame:

Frame is welded chromemolybdenum steel.
 Pivoting rear arm in rubber bushings.

Front fork:

Oil-damped telescopic fork, 7 inches
 movement. Oil capacity: 6oz (0,2 litre)
 per fork leg. Oil recommendation: Engine
 oil SAE 20-50 depending on temperature,
 rider and course.

Wheels:

Front: 3.00x 21" with moto-cross tyre.
 Rear: 4.00x18" with moto-cross tyre for 250
 4.50x18" with moto-cross tyre for 400&501

Brakes:

rear: diam. 160x30 mm (6 5/16"x1 3/16")
 front: diam. 140x30 mm (5 1/2"x1 3/16")

Saddle:

Moto-cross type.

Footrests:

Folding footrests at a 45° angle.

Fuel tank:

Fiberglass fuel tank
 Capacity: 7 liter (1.9 Gals)

Dimensions:

Wheelbase: 54" (1375 mm)
 Saddle height: 31.5" (800 mm)
 Ground clearance: 7" (180 mm)
 Dry weight: 250cc: 102 kg (224 lb.)
 400cc: 105 kg (231 lb.)
 501cc: 107 kg (239 lb.)

Screwed joints:

Nut for magneto: 10 lb.ft. (1.7kpm)
 Nut for output chainsprocket: 50 lb.ft. (7kpm)
 Nuts which hold the cylinder head to the
 cylinder: 15 lb.ft. (2.5kpm) for 250 & 400;
 25 lb.ft. (3.5kpm) for 501
 Engine mounting bolts: 25 lb.ft. (3.5kpm) 8mm bolts
 35 lb.ft. (5.2kpm) for 10mm bolts
 Nuts which hold the bearing bolts for the rear
 wheel pivot arm: 25 lb.ft. (3.5kpm)
 Clutch nut - 30 foot lbs.
 Engine sprocket nut - 35-45 foot lbs.
 Counter shaft nut - 40-50 foot lbs.